

UNCLE ELCHEAPO CORNER

Corporate sponsors of egglofting

Health insurance companies, credit card megacorporations, phone companies, all too poor to provide honest and quality service, yet somehow they manage to send us every month a glossy colorful brochure with even more promises and artfully twisted facts.

If you've been throwing those brochures away to keep your blood pressure where your doctor wants to see it, you've been deliberately robbing yourself of one of the best materials for egglofter shrouds. Colorful and glass smooth are exactly properties that you want for your egglofter.

While the discussion about benefits of shrouded egglofters vs. egg-on-stick models is still bubbling hot, the fact is that shrouded models are marking sky at ribbon deserving altitudes or provide ample payload space for huge chutes so needed in eggloft duration events. One fine example of a competitive shrouded egglofter is Eggstravaganza model. You can find detailed plans of it in the May/June issue of the 2001 volume of The WOOSH Pop.

Creating a well fitting shroud requires some math and some dexterity, but it can be mastered in relatively low number of attempts. Let's take the look at math part first.

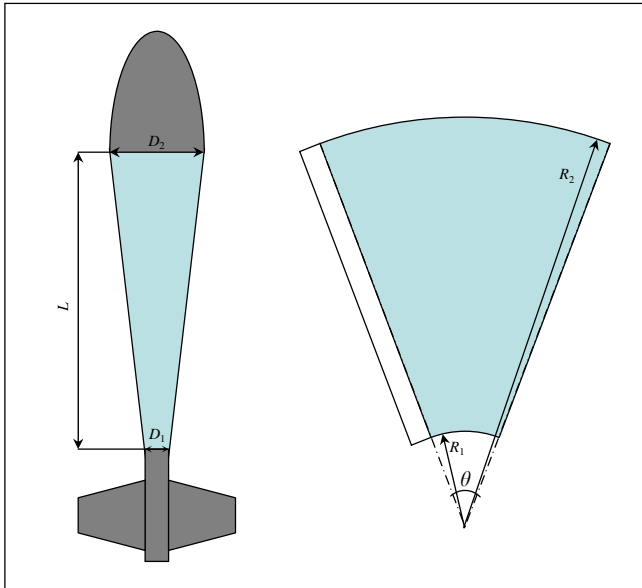

We know diameters on both ends (wide (D_2) and narrow (D_1)) and also the desired length of the shroud (L). Longer shrouds provide more payload capacity, shorter shrouds are best for altitude models. The common mistake is to fly a duration egglofter in altitude event (you do not need 50" chute to recover the egg safely and the extra friction really hurts your altitude).

To create the shroud we draw two concentric circular arcs and then cut a wedge of an exact angle (see the picture). What are the radiuses for arcs (R_1, R_2) and what is the angle (Θ) comes out from the following equations (do not be afraid, just start with top left equation, plug in the numbers, compute the result and follow the arrow to the next equation, and so on...). Make sure you use the same units for all measurements. The Θ angle will be in degrees.

$$X = \frac{D_2 - D_1}{2} \rightarrow Y = \sqrt{L^2 + X^2} \rightarrow R_1 = \frac{Y \times D_1}{(D_2 - D_1)} \rightarrow$$

$$R_2 = \frac{Y \times D_2}{(D_2 - D_1)} \rightarrow \Theta = \frac{180 \times D_2}{R_2} \rightarrow \int_0^\pi \left(\frac{\text{waituntilyour}}{\text{headstopspinning}} \right)$$

Wasn't that difficult, was it? Now we know radiuses for both inner and outer edge of the shroud and also the angle of the wedge. Before you get to work (the dexterity part), do not forget that you have to leave some overlap, otherwise you will not be able to glue the shroud together (picture is worth thousand words, so take another look).

Gluing the shroud together may be frustrating at first, but you will find your way. I have heard many tricks how to do it easily but I find that the most easy is actually to suffer through the first shroud and after that it becomes easier and easier.

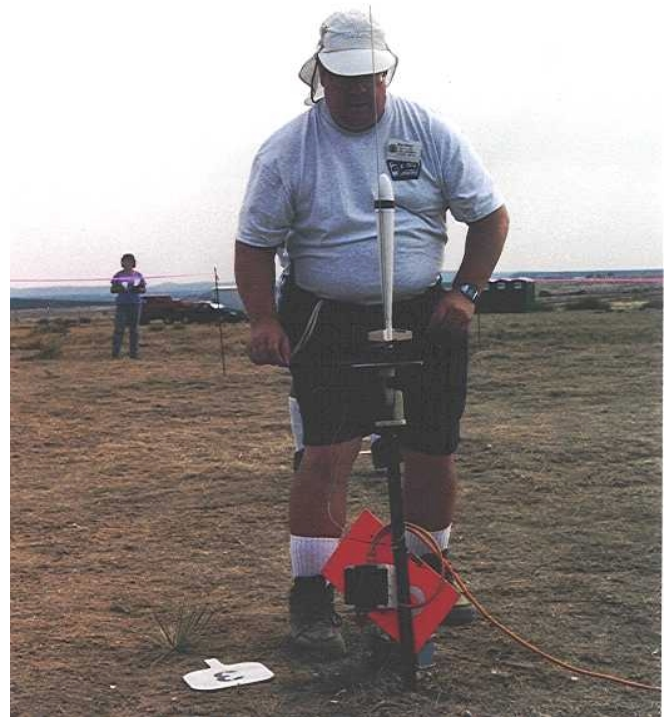

An example of shrouded egglofter from NARAM42 contest range (photo archive)